



ISCOM GPR01 GPON Remote Device

▼ Introduction

The Passive Optical Network (PON) is a power-limited system, of which the channel loss during transmission determines the optical splitting ratio and transmission distance. The Reach Extension (RE) technology is thus generated to address the limited optical splitting ratio and transmission distance problem in the PON. The essence of the RE is to deploy active devices in the PON, which increases optical budget and thus increases the optical splitting ratio and transmission distance.

The Raisecom ISCOM GPR01 adopts the Optical-Electrical-Optical (OEO) regeneration technology to implement Regeneration, Reshaping, and Retiming (3R) amplification of signals, thus able to amplify the optical power of GPON links, prolong transmission distance, and increase optical splitting ratio. With small size and easy installation, the ISCOM GPR01 can be widely used in various GPON scenarios, such as radio&television, Customer Premise Network (CPN), carriers, power grid, and transportation.

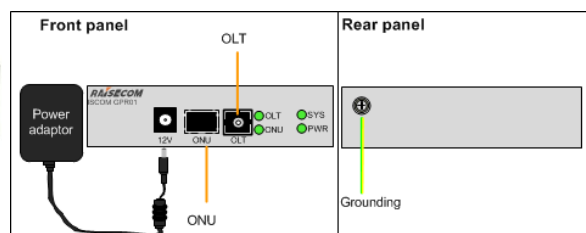

▼ Highlights

- Support amplifying optical power of GPON lines and transmitting services transparently.
- Support 3R amplification with extracted clock signals.
- Support expanding coverage and prolonging transmission distance to 40 km in cooperation with Raisecom GPON system.
- Support flexible networking by cascading multiple devices in serial or parallel mode.
- Support saving OLTs, prolonging networking distance, and increasing optical splitting ratio.
- Support easy installation, convenient maintenance, and plug and play.
- Support deployment in any location free of limit by NEs.
- Support lowering cost to maximum investment return.



▼ Specifications

Transmission	
Supported protocol	ITU-T G.984.x
Uplink rate	1.25 Gbit/s burst signals
Downlink rate	2.5 Gbit/s continuous signals
Networking features	Support amplifying optical signals of any relay in the GPON network. Support cascading up to 3 amplifiers. Support 1:63+1:32 optical splitting ratio for network expansion.
Compatibility	Support transparent transmission of services.
Transmission distance	Up to 40 km in cooperation with Raisecom GPON system
Optical interface parameters	
OLT-side Rx sensitivity	-28 dBm
ONU-side Rx sensitivity	-28 dBm
OLT-side Tx optical power	0.5–5 dBm
ONU-side Tx optical power	1.5–5 dBm
Environment	
Dimensions	200 mm (Length) × 130 mm (Width) × 32 mm (Height)
Overall power consumption	≤ 10 W
Operating voltage	12 VDC
Operating current	1 A
Operating temperature	-10 °C to 55 °C
Storage temperature	-40 °C to 60 °C

➤ **Note:**

- ✓ The ISCOM GPR01 is an active device, requiring 220 VAC power input, or redundancy power supply if allowed.
- ✓ It supports up to 40 km absolute/differential distance in cooperation with Raisecom GPON system.
- ✓ It requires configuration of OLT parameters (such as RTT), which are available from R&D department.



▼ Typical applications

➤ **Typical application networking**

The ISCOM GPR01 can be deployed between the OLT and ONU, with typical application networking below.

1. It is deployed between the OLT and optical splitter to increase the optical budget of the trunk, as well as the trunk of the ODN. It was initially deployed in the trunk.

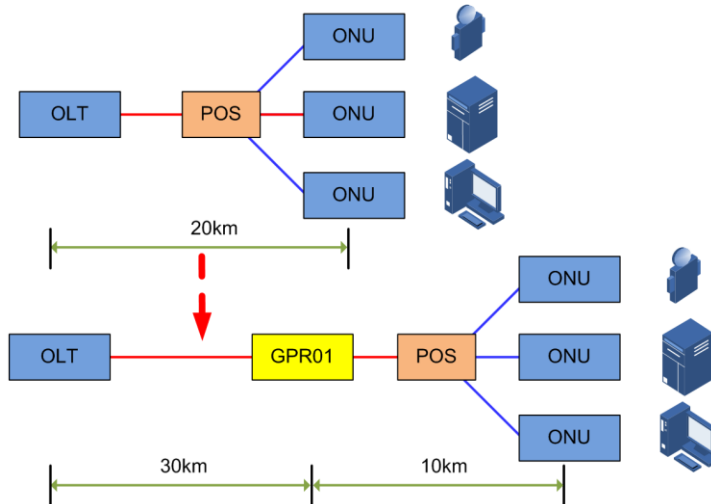

2. It is deployed between the OLT and optical splitter to increase optical splitting ratio, which can resolve the optical splitting ratio limit problem due to inadequate optical budget.

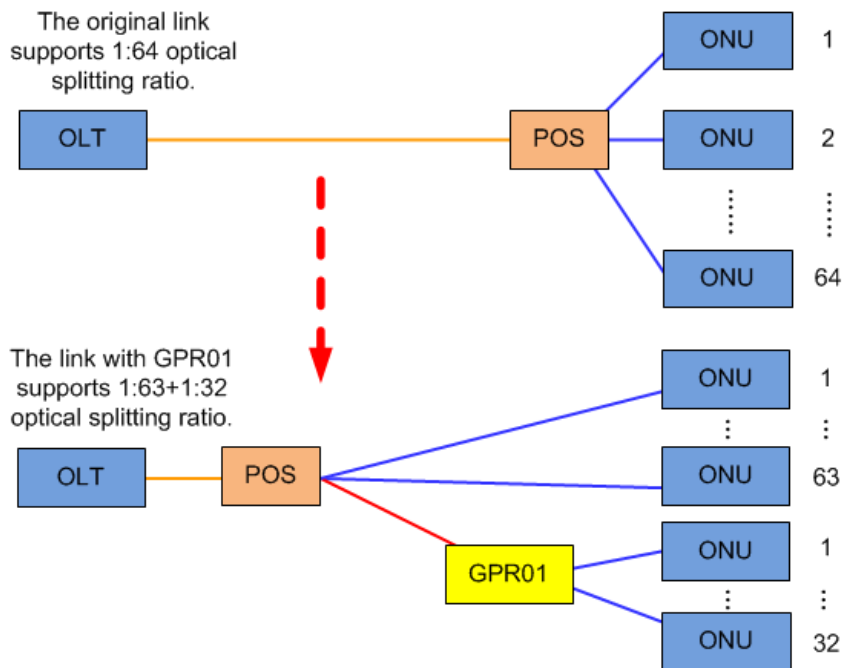

➤ **Significance**



Introduction of the RE technology enables the PON system to amplify optical signals at one or more levels as required to prolong the transmission distance and increase optical splitting ratio; in addition, it does not change the basic structure of the PON system, so it is well compatible with existing NEs, thus relieving deployment of the PON system. In a word, the RE technology is significant prolonging transmission distance, increasing optical splitting ratio, improving ODN flexibility, and lowering cost.

1. Adapting to changes in MAN structure

As the MAN advances, the OLT is deployed closer to the BRAS/SR. With consideration of the transmission distance between the OLT and ONU, optical splitter, and other link losses, the optical budget needs to be increased by about 20 dB, which can be satisfied by the RE technology applied to the GPON.

2. Adapting to cost increment due to low port utilization

A large number of new buildings adopt FTTH/FTTB and the Customer Premise Network (CPN), such as fiber and copper wire, yet with low port utilization now or later. To save Trunk fiber and OLT ports, a network with wider coverage and flexible access methods is required, which can be implemented by the RE technology.

3. Addressing special requirements from industry network

An OLT in some applications, such as video monitoring, transportation safeguard, automatic power distribution, and sensor network, is always connected with a large number of ONUs which are widely scattered, and some ONUs are far away from the OLT, which can be solved by fiber RE in the PON system.

4. Lowering overall cost on network construction

The RE technology has the following impacts on network construction cost:

- ✓ The ascending of the OLT deployment location helps lowering cost on constructing the switching network.
- ✓ Increment of port utilization lowers overall cost on PON construction.
- ✓ Introduction of the RE technology will bring cost on managing and maintaining remote devices.

5. Extendibility and sustainable development of future network

The RE technology increases the optical budget, prolongs transmission distance, and enriches application scenarios, which makes service expansion and network construction more convenient and flexible, especially in vast areas or rapidly growing areas. To sum up, the RE technology is vital to the access network and carriers, as well as a breakthrough for planning and deploying future networks.

▼ Ordering information

Model	Description
ISCOM GPR01	With one OLT interface and one ONU interface. Purchase the GPON OLT optical module by yourself.
GSFP-CLBDM-R	Commercial GPON OLT optical module, complying with CLASS B+ standard
GSFP-CLCDM-R	GPON OLT optical module (SFP, commercial), complying with CLASS C+ standard